

**Test Description**

Number(s) below refer to the step number(s) on the Diagnostic Table.

1. The On-Board Diagnostic (EOBD) System Check prompts the technician to complete some basic checks and store the freeze frame and failure records data on the scan tool if applicable. This creates an electronic copy of the data taken when the malfunction occurred. The information is then stored on the scan tool for later reference.
4. This step checks to see if the HO2S1 is operating properly.
6. If no faults have been found at this point and no additional DTCs were set, refer to "[Diagnostic Aids](#)" in this section for additional checks and information.

**DTC P1166 - Fuel Trim System Lean During Power Enrichment**

Step	Action	Value(s)	Yes	No
1	Perform an On-Board Diagnostic (EOBD) System Check. Is the system check complete?	-	Go to Step 2	Go to " <a href="#">On-Board Diagnostic System Check</a> "
2	1. Install a scan tool to the Data Link Connector(DLC). 2. Turn the ignition ON.  Are any component related Diagnostic Trouble Codes (DTCs) set?	-	Go to applicable DTC table	Go to Step 3
3	1. Check the vehicle for an adequate amount of fuel. 2. Add fuel to the vehicles fuel tank if the tank is almost empty.  Did the fuel tank require fuel?	-	Go to Step 5	Go to Step 4
4	1. Using a scan tool, observe the Front Heated Oxygen Sensor (HO2S1) voltage while accelerating the engine over 1200 rpm. 2. The HO2S1 voltage should vary from specified voltage (100-900 mV) and occasionally toggle above the specified voltage while accelerating.  Is the HO2S1 voltage toggle?	3507 mV	Go to " <a href="#">Fuel System Diagnosis</a> "	Go to " <a href="#">DTC P0134 Oxygen Sensor No Activity</a> "
5	1. Using the scan tool, clear the Diagnostic Trouble Codes (DTCs). 2. Start the engine and idle at normal operating temperature. 3. Operate the vehicle within the conditions for setting this DTC as specified in the supporting text.  Does the scan tool indicate that this diagnostic has run and passed?	-	Go to Step 6	Go to Step 2
6	Check if any additional DTCs are set. Are any DTCs displayed that have not been diagnosed?	-	Go to Applicable DTC table	System OK

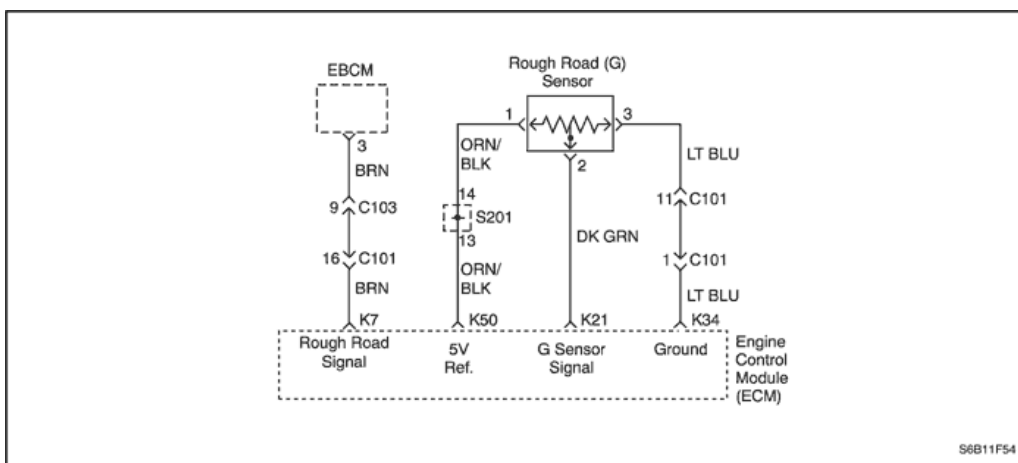

**Diagnostic Trouble Code (DTC) P1391**

**Rough Road Sensor Performance**

**Circuit Description**

The Gravity Sensing Rough Road (G) sensor is a vertical low g-acceleration sensor. By sensing vertical acceleration caused by bumps or potholes in the road, the Engine Control Module (ECM) can determine if the changes in crankshaft speed are due to engine misfire or air

driveline induced. If the G sensor detects a roughroad condition, the ECM misfire detection diagnostic will be de-activated. The G sensor at rest output should be between 2.35-2.65 volts (+1G). During a rough road condition, the voltage output can vary between 0.5(-1G) and 4.5 volts (+3G).

**Conditions for Setting the DTC**

- Engine is running.
- Vehicle speed is less than or equal to 5 km/h (3.1mph).
- G sensor output at idle indicates below -0.39 volts or above 2.21 volts.

OR

- Engine is running more than 10 seconds and vehicle speed is between 30 mph (50 km/h) and 70 mph (112km/h).
- G sensor signal changes less than 0.00024 volts while driving.

**Action Taken When the DTC Sets**

- The Malfunction Indicator Lamp (MIL) will not illuminate.
- The ECM will record operating conditions at the time the diagnostic fails. This information will be stored in the Freeze Frame and Failure Records buffers.
- A history DTC is stored.

**Conditions for Clearing the MIL/DTC**

- A history Diagnostic Trouble Code (DTC) will clear after 40 consecutive warm-up cycles without a fault.
- DTC(s) can be cleared by using the scan tool.
- Disconnecting the ECM battery feed for more than 10 seconds.

**Diagnostic Aids**

Check for the following conditions:

- Poor connection at the ECM - Inspect the harness connections for backed-out terminals, improper mating, broken locks, improperly formed or damaged terminals, and poor terminal-to-wire connection.
- Damaged harness – Inspect the wiring harness for damage. If the harness appears to be OK, observe the G sensor display on the scan tool while moving connectors and wiring harnesses related to the sensor. A change in the display will indicate the location of the fault.

Since the G sensor shares the ECM 5 volt reference and ground terminals with the A/C Pressure Sensor, a damaged A/C Pressure Sensor harness or sensor could cause a G sensor DTC to set. Refer to "[Multiple ECM Information Sensor DTCs Set](#)" in this section in this section.

The G sensor will give correct voltages only if it is level and mounted securely to its bracket.

Reviewing the Failure Records vehicle mileage since the diagnostic test last failed may help determine how often the condition that caused the DTC to be set occurs. This may assist in diagnosing the con

**Test Description**

The number(s) below refer to step(s) on the diagnostic table.

1. The On-Board Diagnostic (EOBD) System Check prompts the technician to complete some basic checks and store the freeze frame and failure records data on the scan tool if applicable. This creates an electronic copy of the data taken when the malfunction occurred. The information is then stored on the scan tool for later reference.

**DTC P1391 - Rough Road Sensor Performance**

Step	Action	Value(s)	Yes	No
1	Perform an On-Board Diagnostic (EOBD) System Check. Is the system check complete?	-	Go to Step 2	Go to " <a href="#">On-Board Diagnostic System Check</a> "
2	1. Turn the ignition ON, with engine OFF. 2. Install a scan tool to the Data Link Connector(DLC). 3. Review and record the scan tool Failure Records data. 4. Operate the vehicle within Failure Records conditions as noted. 5. Using the scan tool, monitor specific Diagnostic Trouble Code (DTC) info for DTC P1391.  Does the scan tool indicate that DTC P1391 failed?	-	Go to Step 4	Go to Step 3
3	Check for the following conditions and repair as needed:  <ul style="list-style-type: none"> <li>• G sensor seal missing or damaged.</li> <li>• G sensor mounting flanges cracked, missing, or incorrectly installed.</li> </ul> Is the repair complete?	-	Go to Step 14	Go to " <a href="#">Diagnostic Aids</a> "

Step	Action	Value(s)	Yes	No
4	<ol style="list-style-type: none"> <li>1. Turn the ignition OFF.</li> <li>2. Disconnect the G sensor electrical connector.</li> <li>3. Turn the ignition ON, with the engine OFF.</li> <li>4. Observe the G sensor value displayed on the scan tool.</li> </ol> <p>Is the G sensor value near the specified value?</p>	0 v	Go to Step 5	Go to Step 12
5	<ol style="list-style-type: none"> <li>1. Jumper the 5 volt reference circuit, terminal 1 and the G sensor signal circuit, terminal 2 together at the G sensor harness connector.</li> <li>2. Observe the G sensor value displayed on the scan tool.</li> </ol> <p>Is the G sensor value near the specified value?</p>	4.95 v	Go to Step 6	Go to Step 7
6	<ol style="list-style-type: none"> <li>1. Turn the ignition OFF.</li> <li>2. Disconnect the Engine Control Module (ECM) and check the sensor ground circuit for high resistance, an open between the ECM and the G sensor, or for a poor connection at the terminal k34 of the ECM and repair as needed.</li> <li>3. If the problem is found, repair as necessary.</li> </ol> <p>Is a problem found?</p>	-	Go to Step 14	Go to Step 10
7	<p>Check the 5 volt reference circuit for high resistance, an open between the ECM and the G sensor, or a poor connection at the terminal k50 of the ECM and repair as needed.</p> <p>Is the repair complete?</p>	-	Go to Step 14	Go to Step 8
8	<ol style="list-style-type: none"> <li>1. Turn the ignition OFF.</li> <li>2. Disconnect the ECM and check the G sensor signal circuit for high resistance, an open, a short to ground, or a short to the sensor ground circuit and repair as needed.</li> </ol> <p>Is the repair complete?</p>	-	Go to Step 14	Go to Step 9
9	<p>Check the G sensor signal circuit for a poor connection at the ECM and repair as needed.</p> <p>Is the repair complete?</p>	-	Go to Step 14	Go to Step 13
10	<p>Check for a poor connection at terminal 3 of the G sensor and repair as needed.</p> <p>Is the repair complete?</p>	-	Go to Step 14	Go to Step 11
11	<p>Replace the G sensor.</p> <p>Is the repair complete?</p>	-	Go to Step 14	-
12	<ol style="list-style-type: none"> <li>1. Turn the ignition OFF.</li> <li>2. Disconnect the ECM.</li> <li>3. Turn the ignition ON.</li> <li>4. Check the G sensor signal circuit for a short to voltage or a short to the 5 volt reference circuit and repair as needed.</li> </ol> <p>Is the repair complete?</p>	-	Go to Step 14	Go to Step 13
13	<ol style="list-style-type: none"> <li>1. Turn the ignition OFF.</li> <li>2. Replace the ECM.</li> </ol> <p>Is the repair complete?</p>	-	Go to Step 14	-
14	<ol style="list-style-type: none"> <li>1. Using the scan tool, clear the DTCs.</li> <li>2. Start the engine and idle at normal operating temperature.</li> <li>3. Operate the vehicle within the conditions for setting this DTC as specified in the supporting text.</li> </ol> <p>Does the scan tool indicate that this diagnostic ran and passed?</p>	-	Go to Step 15	Go to Step 2
15	<p>Check if any additional DTCs are set.</p> <p>Are any DTCs displayed that have not been diagnosed?</p>	-	Go to Applicable DTC table	System OK

