

22. WIPER/WASHER

1) WIPER/WASHER CIRCUIT

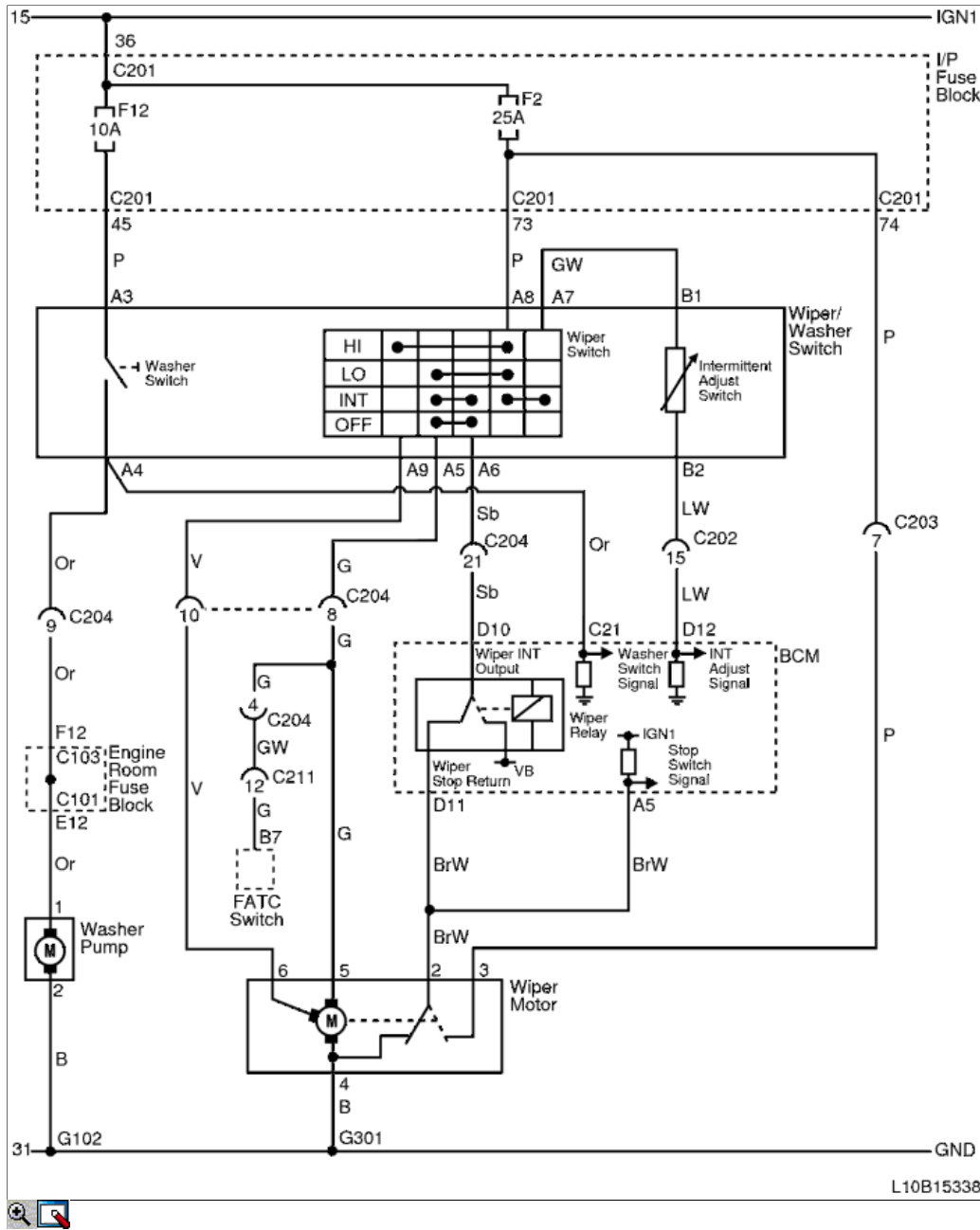

a. CONNECTOR INFORMATION

CONNECTOR NO (PIN NO, COLOR)	CONNECTING WIRING HARNESS	CONNECTOR POSITION
C101 (68 Pin, Black)	Front - Engine room fuse block	Engine room fuse block
C103 (68 Pin, White)	Body - Engine room fuse block	Engine room fuse block
C201 (76 Pin, Black)	IP - I/P fuse block	I/P fuse block
C202 (23 Pin, White)	IP - Body	Connector box at the bottom of left A pillar
C203 (16 Pin, Yellow)	IP - Body	Connector box at the bottom of left A pillar

CONNECTOR NO (PIN NO, COLOR)	CONNECTING WIRING HARNESS	CONNECTOR POSITION
C204 (22 Pin, White)	IP - Body	Connector box at the bottom of left A pillar
C211 (16 Pin, White)	IP - A/C	Behind the glove box
G102	Front	Behind right head lamp
G301	Body	On the left crossmember of front floor panel

b. CONNECTOR IDENTIFICATION SYMBOL & PIN NUMBER POSITION

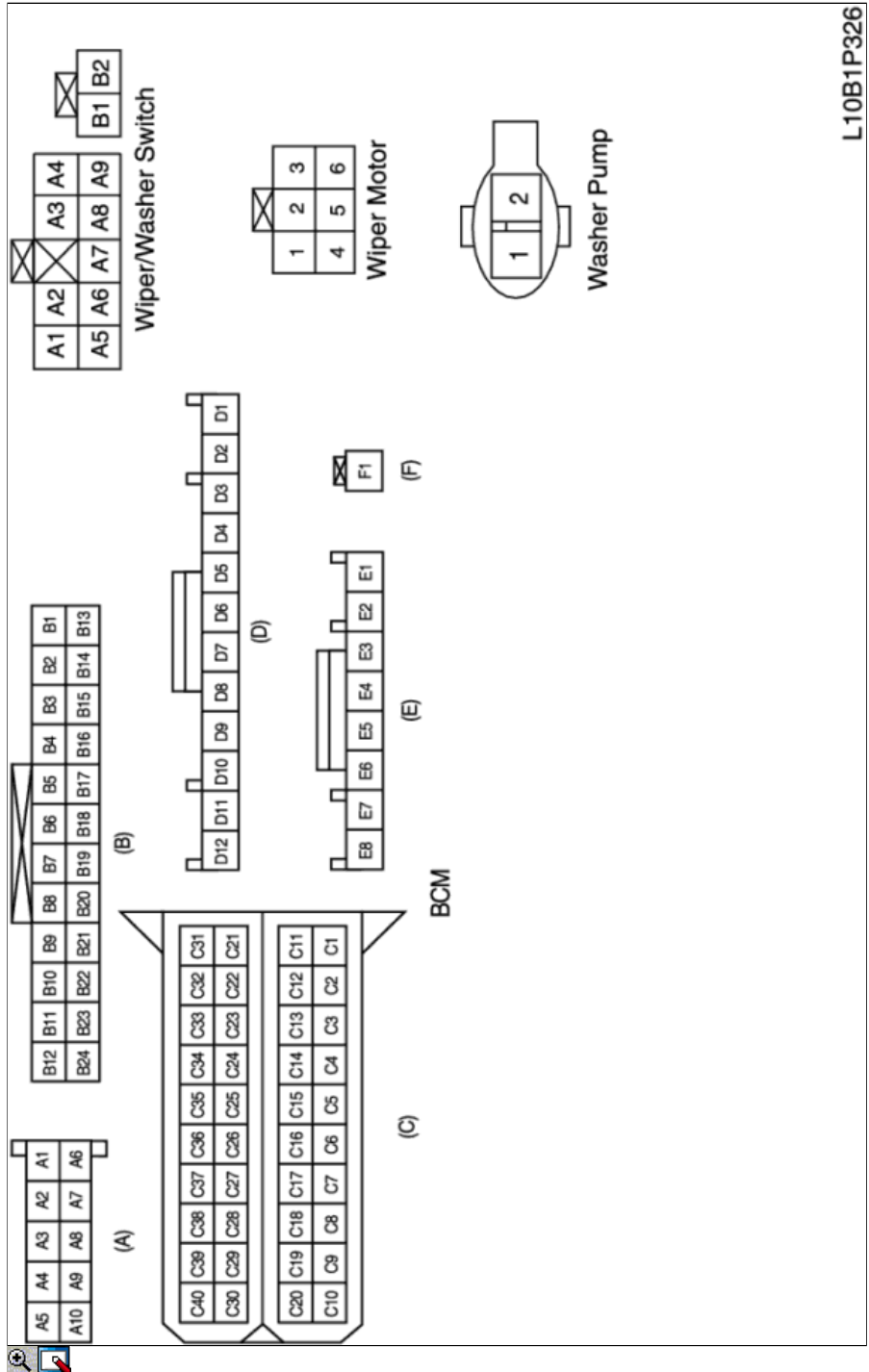

c. POSITION OF CONNECTORS AND GROUNDS

- W/H I/P

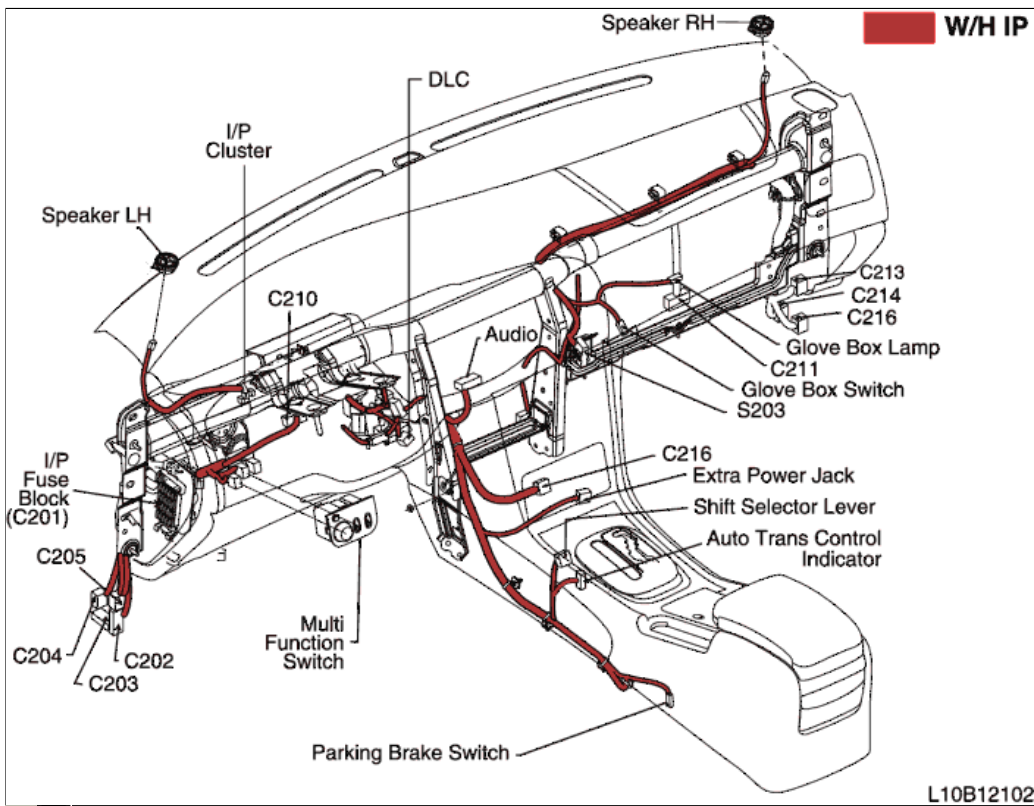

• W/H BODY

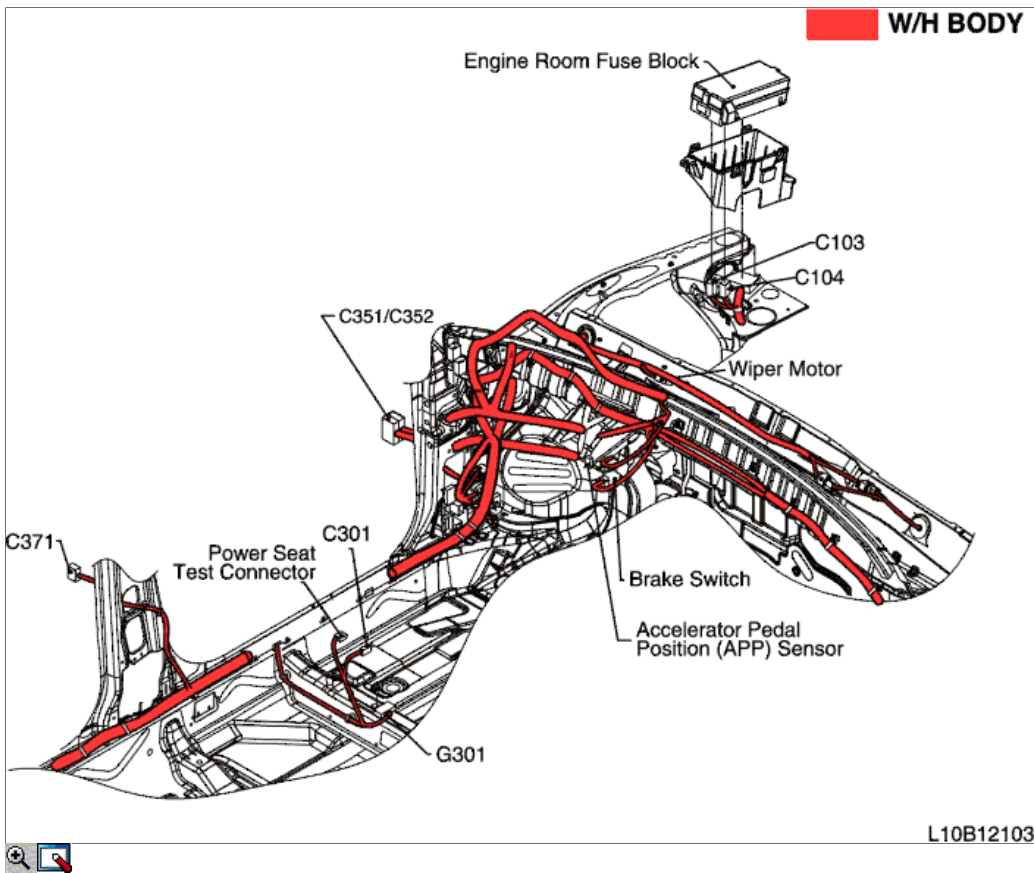

2) RAIN SENSING WIPER/WASHER CIRCUIT

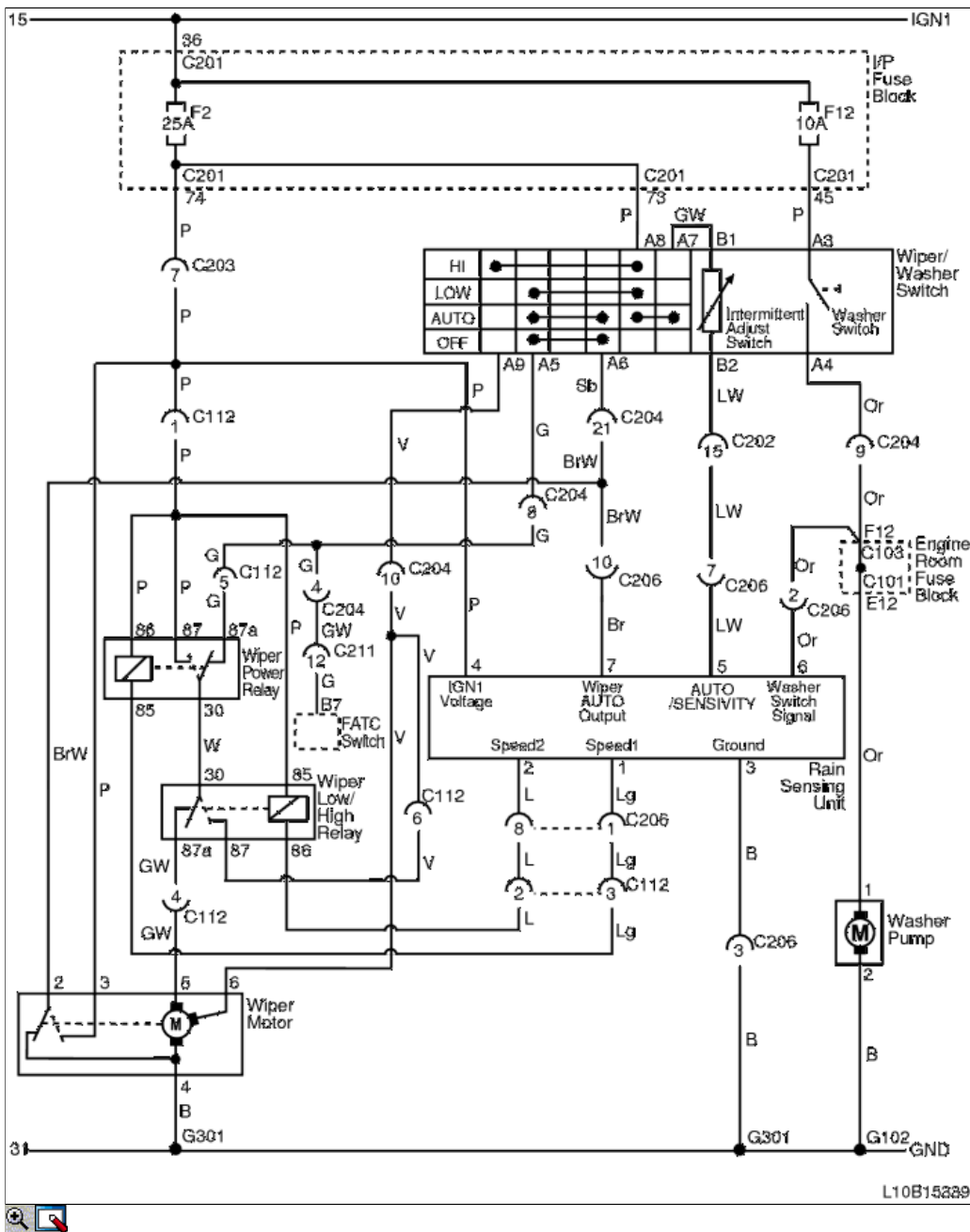

a. CONNECTOR INFORMATION

CONNECTOR NO (PIN NO, COLOR)	CONNECTING WIRING HARNESS	CONNECTOR POSITION
C101 (68 Pin, Black)	Front - Engine room fuse block	Engine room fuse block
C103 (68 Pin, White)	Body - Engine room fuse block	Engine room fuse block
C112 (6 Pin)	Body - Body Sub	Beside wiper motor in cowl panel
C201 (76 Pin, Black)	IP - I/P fuse block	I/P fuse block
C202 (23 Pin, White)	IP - Body	Connector box at the bottom of left A pillar
C203 (16 Pin, Yellow)	IP - Body	Connector box at the bottom of left A pillar
C204 (22 Pin, White)	IP - Body	Connector box at the bottom of left A pillar
C206 (18 Pin, White)	Roof - Body	Near the center of driver A pillar
C211 (16 Pin, White)	IP - A/C	Behind the glove box
G102	Front	Behind right head lamp
G301	Body	On the left crossmember of front floor panel

b. CONNECTOR IDENTIFICATION SYMBOL & PIN NUMBER POSITION

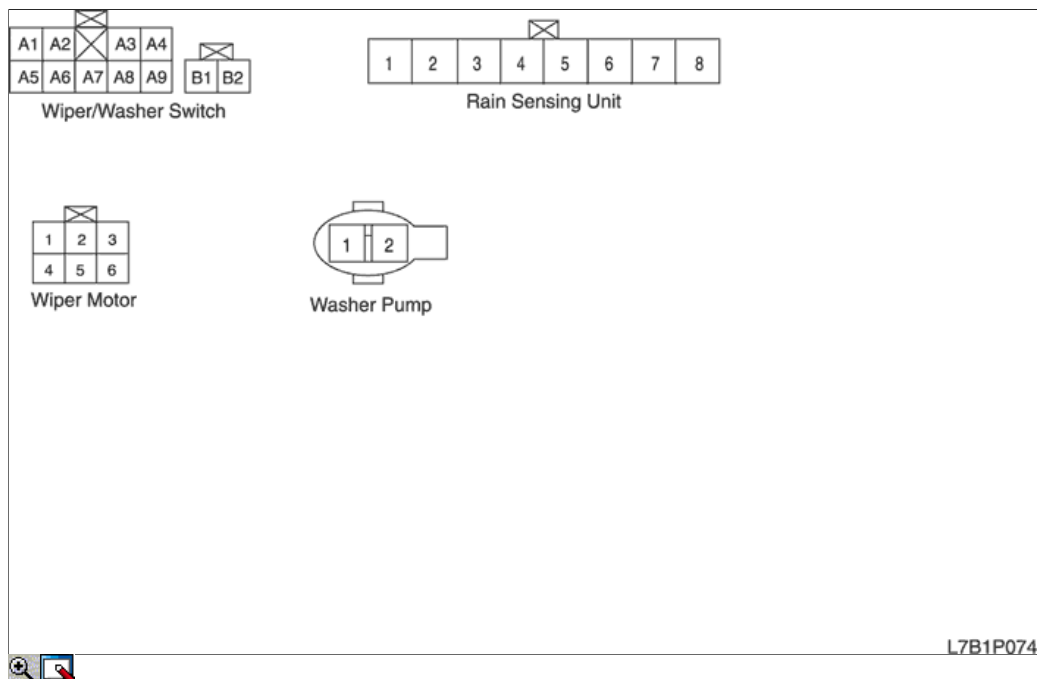

c. POSITION OF CONNECTORS AND GROUNDS

- W/H I/P

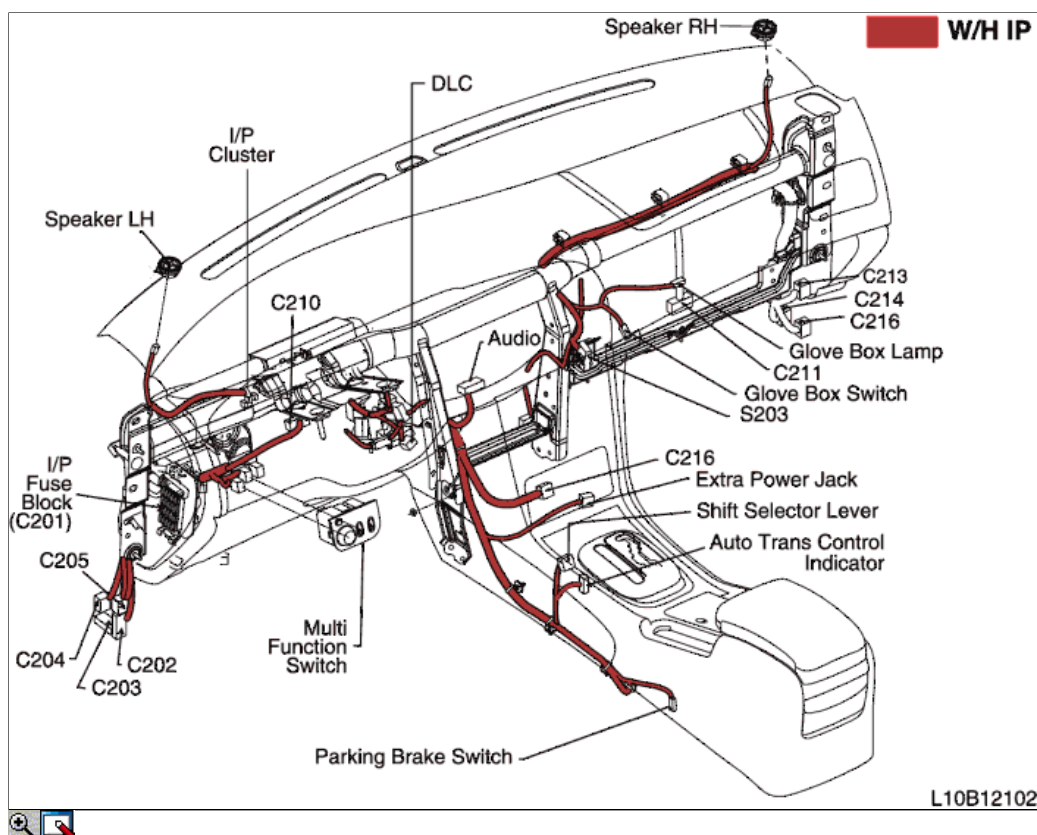

- W/H BODY

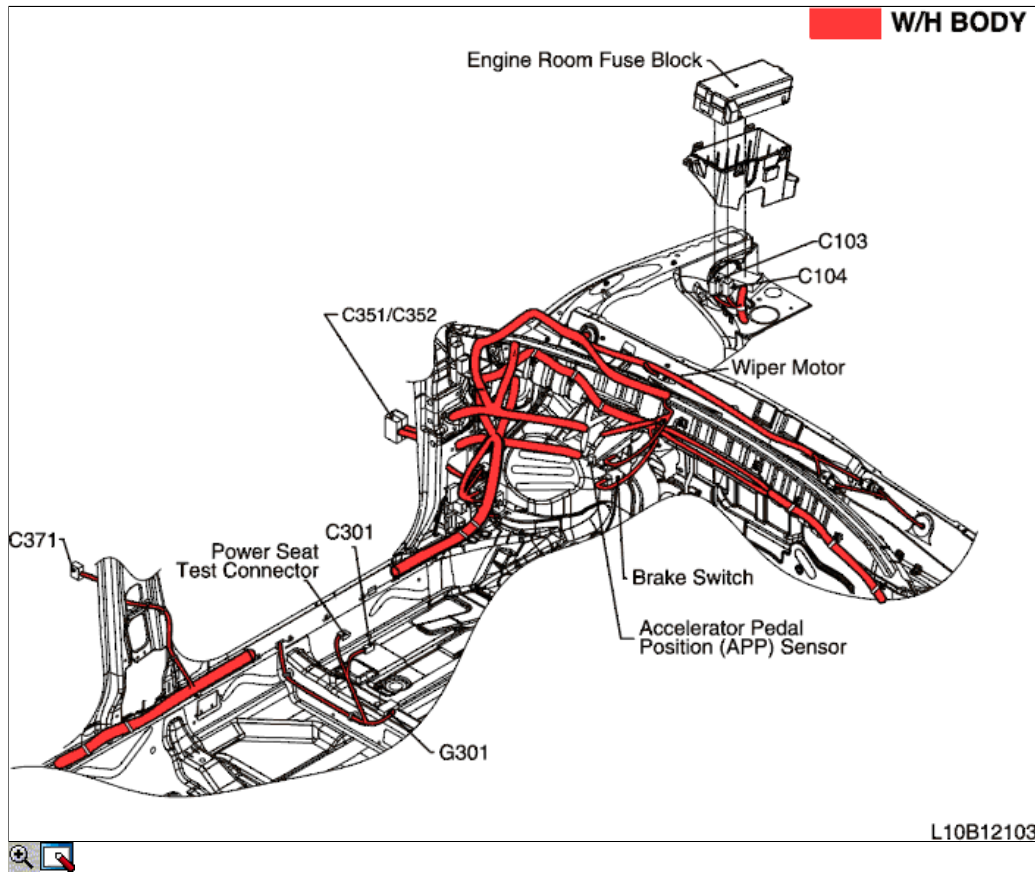

© Copyright Chevrolet Europe. All rights reserved